

REVISIONS

SYM.	DESCRIPTION	DATE	APPROVAL
------	-------------	------	----------

ASSEMBLY INSTRUCTION FOR RG-58/U CABLE

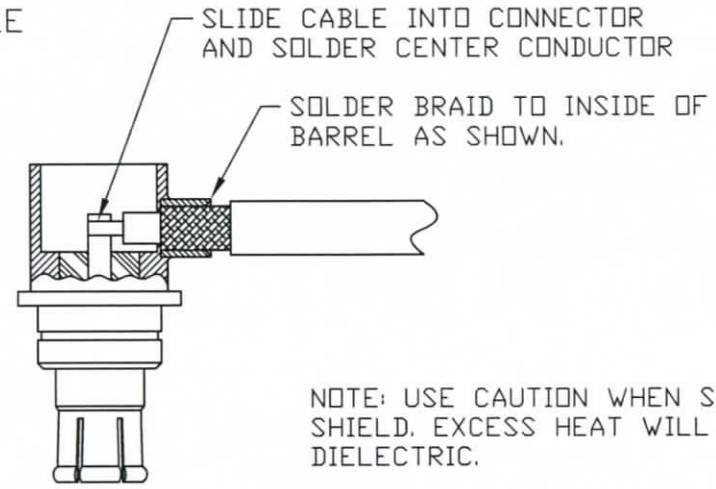
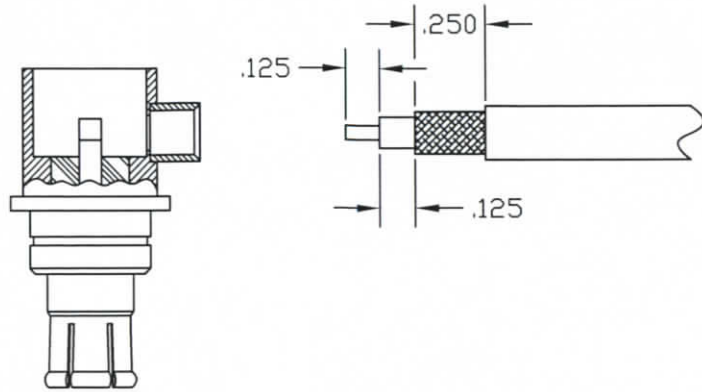

NOTE: USE CAUTION WHEN SOLDERING SHIELD. EXCESS HEAT WILL MELT DIELECTRIC.

ASSEMBLY INSTRUCTION FOR RG-316/U CABLE

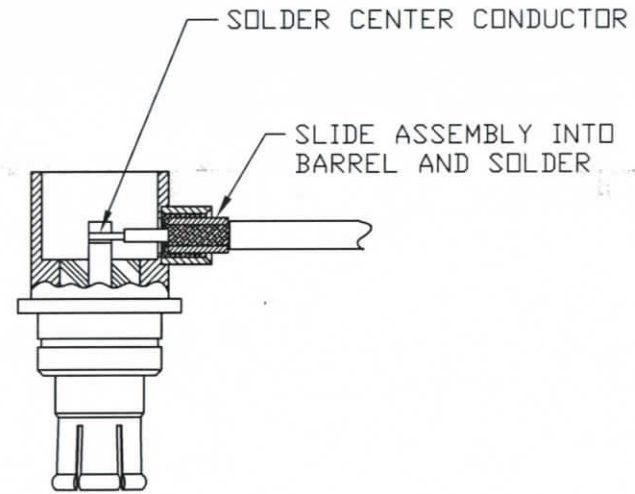
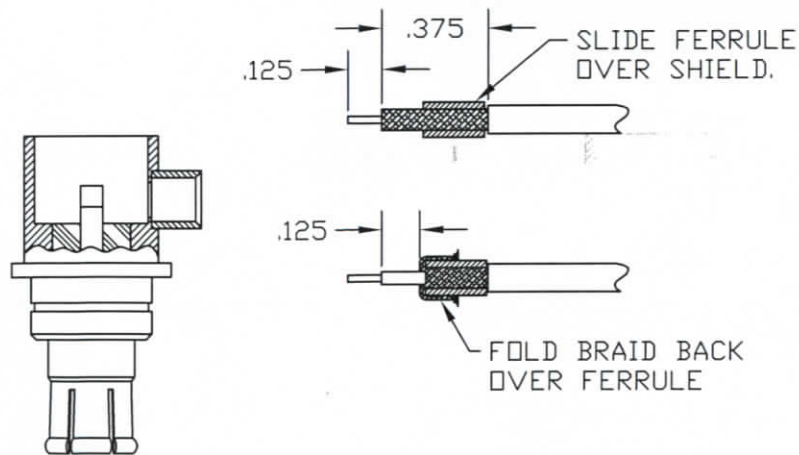

UNLESS OTHERWISE SPECIFIED
DIMENSIONS ARE IN INCHES
FRACTIONS DECIMALS ANGLES
±1/64 ±.005 ± 1°

DR. WEISBACH	DATE 6-10-01
CK. <i>SW</i>	DATE 6-10-01
SHEET 1 OF 2	

TITLE

ASSEMBLY INSTRUCTIONS
FOR 9-30-10

DWG. NO.

700-0101-02

REV.

A

REVISIONS

SYM.	DESCRIPTION	DATE	APPROVAL
------	-------------	------	----------

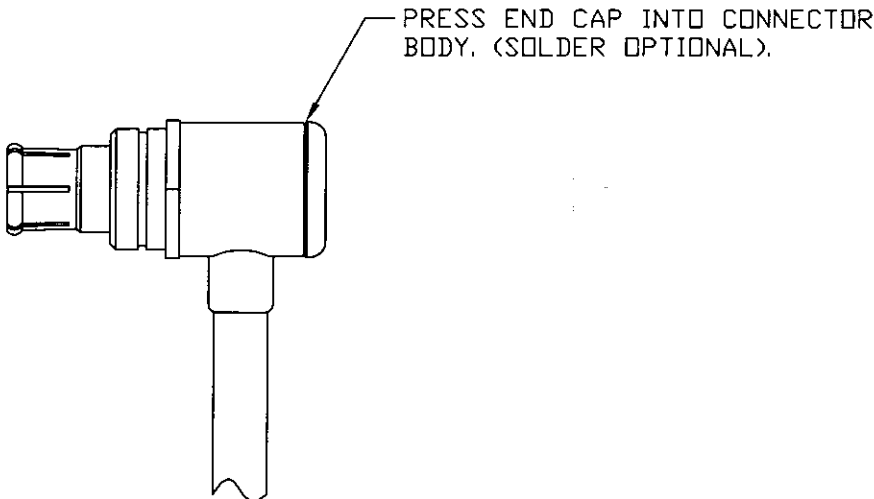
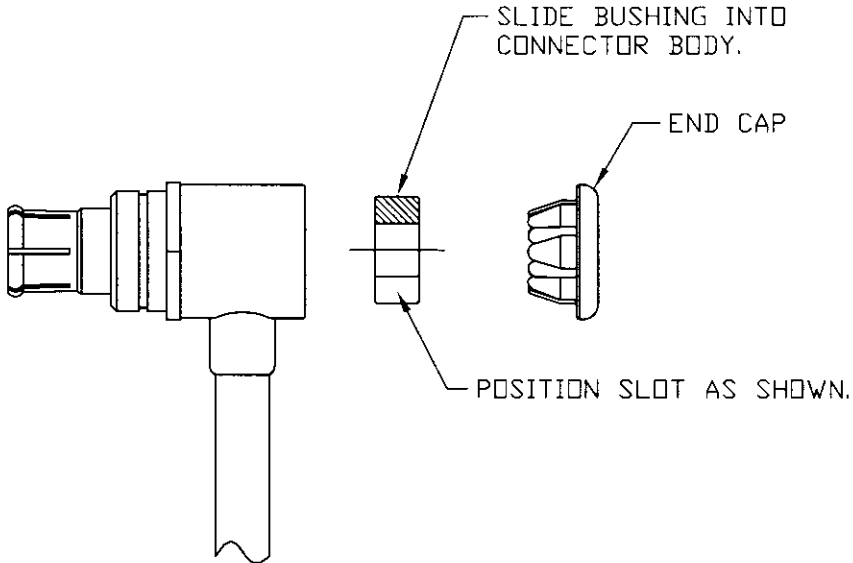

UNLESS OTHERWISE SPECIFIED
 DIMENSIONS ARE IN INCHES
 FRACTIONS DECIMALS ANGLES
 ±1/64 ±.005 ± 1°

DR. WEISBACH	DATE 6-10-01
CK. <i>SW</i>	DATE 6-10-01
SHEET 2 OF 2	

TITLE
 ASSEMBLY INSTRUCTIONS
 FOR 9-30-10

DWG. NO.
 700-0101-02

REV.
 A