

STEINEL®



HL 1610 S

HL 1810 S

HL 1910 E

— HL 2010 E —

HG 2310 LCD

HG 2510 ESD

FUNCTIONAL
12 month
WARRANTY

i

IMPORTANT SAFETY INSTRUCTIONS

READ THESE INSTRUCTIONS

UL WARNING: Read this instruction book before using. To reduce risk of fire or electric shock, do not expose to rain or moisture. Store indoors. Double insulated. When servicing, use only identical replacement parts. When using electric tools, basic safety precautions should always be followed to reduce risk of fire, electric shock and personal injury. This hot air gun operates at 1200°F with no visual indication of temperature (no flame). Never leave device unattended. Otherwise risk of fire. The heat stream at the outlet nozzle will burn flesh. Do not turn on heat gun with hand in front of nozzle. **DO NOT USE NEAR COMBUSTIBLE LIQUIDS. DO NOT USE FOR:** ● Heating gas engines ● Heating car batteries ● Thawing refrigerator equipment.

WARNING: Some dust created by power sanding, sawing, grinding, drilling and other construction activities contains chemicals known (to the State of California) to cause cancer, birth defects, or other reproductive harm. Some examples of these chemicals are:

- lead from lead-based paints,
- crystalline silica from bricks and cement and other masonry products, and
- arsenic and chromium from chemically-treated lumber.

Your risk from these exposures varies, depending on how often you do this type of work. To reduce your exposure to these chemicals: work in a well ventilated area, and work with approved safety equipment, such as those dust masks that are specially designed to filter out microscopic particles.

WARNING!

This tool is capable of producing temperatures up to 1200° F of flameless heat at the nozzle. **ALWAYS:**

- Direct the heat away from yourself and others.
- Prevent ignition of combustible materials on or near the workpiece.
- Prevent blockage of intake and nozzle openings.
- Keep a fully charged fire extinguisher on hand.
- Allow the nozzle and accessory tips to cool to room temperature before storage.

Cautions

1. **WARNING:** Hidden areas such as behind walls, ceilings, floors, soffit boards and other panels may contain flammable materials that could be ignited by the heat gun when working in these locations. The ignition of these materials may not be readily apparent and could result in property damage and injury to persons. Do not use if in doubt about this hazard. When working in these locations, keep the heat gun moving in a back-and-forth motion. Lingering or pausing in one spot could ignite the panel or the material behind it.
2. This heat gun can produce up to 1200° F of flameless heat at the nozzle. Do not direct airstream at clothing, hair or other body parts. Do not use as a hair dryer.
3. Do not use near flammable liquids or in an explosive environment (fumes, gases or dust). Remove materials or debris, that may become ignited, from work area.
4. Always hold tool by plastic enclosure. The metal nozzle requires approximately 20 minutes to cool to where it can be touched. Do not touch nozzle or accessory tips until cool.
5. Do not store tool until nozzle has cooled to room temperature. Place tool in a clear area away from combustible materials while cooling.
6. Do not cut off airflow by placing nozzle too close to workpiece. Keep intake vents clean and clear of obstructions.
7. Place tool on a level surface with the support rubber ring when tool is not hand held. Place cord in a position that won't cause tipping.
8. Do not leave tool unattended while running or cooling down. Otherwise risk of fire.
9. Keep a fully charged fire extinguisher nearby.
10. Do not direct airflow directly on glass.
11. Shield materials around the heated area to prevent damage or fire.
12. Use only with 120 V AC voltage.
13. Do not use in wet conditions.
14. Not to be used by children. This is not a toy and should be respected.
15. Do not use in bath or over water.
16. Safety glasses should be worn when using this tool.
17. It is recommended that leather gloves be worn when using a heat gun.

18. Always unplug after use.
19. **WARNING:** Extreme care should be taken when stripping paint. The peelings, residue and vapors of paint may contain lead, which is poisonous. Any pre-1977 paint may contain lead and paint applied to homes prior to 1950 is likely to contain lead. Once deposited on surfaces, hand to mouth contact can result in the ingestion of lead. Exposure to even low levels of lead can cause irreversible brain and nervous system damage; young and unborn children are particularly vulnerable. Before beginning any paint removal process you should determine whether the paint you are removing contains lead. This can be done by your local health department or by a professional who uses a paint analyzer to check the lead content of the paint to be removed. **LEAD-BASED PAINT SHOULD ONLY BE REMOVED BY A PROFESSIONAL AND SHOULD NOT BE REMOVED USING A HEAT GUN.**

Persons removing materials should follow these guidelines.

1. Move the work piece outdoors. If this is not possible, keep the work area well ventilated. Open the windows and put an exhaust fan in one of them. Be sure the fan is moving the air from inside to outside.
2. Remove or cover any carpets, rugs, furniture, clothing, cooking utensils and air ducts.
3. Place drop cloths in the work area to catch any residue. Wear protective clothing such as extra work shirts, overalls and hats.
4. Work in one room at a time. Furnishings should be removed or placed in the center of the room and covered. Work areas should be sealed off from the rest of the dwelling by sealing doorways with drop cloths.
5. Children, pregnant or potentially pregnant women and nursing mothers should not be present in the work area until the work is done and all clean up is complete.
6. Wear a dust respirator mask or a dual filter (dust and fume) respirator mask which has been approved by the Occupational Safety and Health Administration (OSHA), the National Institute of Safety and Health (NIOSH), or the United States Bureau of Mines. These masks and replaceable filters are readily available at major hardware stores. Be sure the mask fits. Beards and facial hair may keep masks from sealing properly. Change filters often. **DISPOSABLE PAPER MASKS ARE NOT ADEQUATE.**
7. Use caution when operating the heat gun. Keep the heat gun moving as excessive heat will generate fumes which can be inhaled by the operator.
8. Keep food and drink out of the work area. Wash hands, arms and face and rinse mouth before eating or drinking. Do not smoke or chew gum or tobacco in the work area.
9. Clean up all removed residue and dust by wet mopping the floors. Use a wet cloth to clean all walls, sills and any other surface where residue or dust is clinging. **DO NOT SWEEP, DRY DUST OR VACUUM.** Use a high phosphate detergent or trisodium phosphate (TSP) to wash and mop areas.
10. At the end of each work session put the residue and debris in a double plastic bag, close it with tape or twist ties, and dispose of properly.
11. Remove protective clothing and work shoes in the work area to avoid carrying dust into the rest of the dwelling. Wash work clothes separately. Wipe shoes off with a wet rag that is then washed with the work clothes. Wash hair and body thoroughly with soap and water.

SAVE THESE INSTRUCTIONS

Double Insulated Tools

Tools marked with the words "Double Insulated" are equipped with a two prong plug. These tools have a special insulation system that complies with applicable UL standards  1817E. They do not require grounding. "Double Insulated" tools, like this one, have two prong cords and can use either a two or three prong extension cord.

"This appliance has a polarized plug (one blade is wider than the other). To reduce the risk of electric shock, this plug is intended to fit in a polarized outlet only one way. If the plug does not fit fully in the outlet, reverse the plug. If it still does not fit, contact a qualified electrician. Do not modify the plug in any way."

Extension Cords

As the distance from the supply outlet increases, heavier gauge extension cords are required. The use of extension cords of inadequate size wire causes a serious drop in voltage and loss of power. Protect the cord from damage. Keep cords away from excessive heat, sharp edges and damp or wet areas. Repair or replace damaged extension cords before using.

Ext. Cord Length	Wire Size
40 Ft.	16
85 Ft.	14
100 Ft.	12
170 Ft.	10
270 Ft.	8
400 Ft.	6
650 Ft.	4

Note: The HG 2510 ESD is not "Double Insulated". It utilizes a 3-prong grounded plug and, for safety, must only be used with a 3-prong extension cord.

Thank you

for deciding to choose a STEINEL heat gun. This tool can be used for completing a wide range of jobs safely and reliably, such as soldering, welding PVC, shaping,

drying, shrink-fitting, stripping paint etc. All STEINEL tools are manufactured to the highest standards and undergo a strict process of quality control.

Used in the proper manner, this heat gun will give you lasting satisfaction.

Technical specifications

	HG 2510 ESD	HG 2310 LCD	HL 2010 E	HL 1910 E	HL 1810 S	HL 1610 S
Voltage	120 V, 60 Hz	120 V, 60 Hz	120 V, 60 Hz	120 V, 60 Hz	120 V, 60 Hz	120 V, 60 Hz
Output	1600 W	1600 W	1500 W	1500 W	1400 W	1300 W
Switch stage	1 2	1 2	1 2 3	1 2 3	1 2 3	1 2
Airflow (cf/min.)	3.6 3.6 – 176	3.6 3.6 – 176	3.6 10.6 176	3.6 10.6 176	3.6 10.0 15.9	8.5 14.8
Temperature	120 ° 120 – 1200 °F	120 ° 120 – 1200 °F	120 ° 120 – 1150 °F	120 ° 120 – 1100 °F	120 ° 750° 1100 °F	575 ° 950 °F
Controls	pushbutton air/temperature control in 10 °F increments, with LCD display	pushbutton air/temperature control in 10 °F increments, with LCD display	pushbutton temperature control in 10 °F increments, with LCD display	temperature dial	-	-
Programs	4 preset programs, with "LOC" Lockable Override Control™	4 preset programs, with "LOC" Lockable Override Control™	-	-	-	-
Subject to technical modifications						

Conversion °C to °F

°C	= °F
100	212
200	392
300	572
400	752
500	932
600	1112
700	1292

Conversion °F to °C

°F	= °C
100	38
200	93
300	149
400	204
500	260
600	316
700	371
800	427
900	482
1000	538
1100	593
1200	649

Features - Getting started

Please note: The distance from the object you are working on depends on material and intended method of working. Always try out the airflow and temperature on a test piece first! Using the attachable accessory nozzles (see accessories page on the cover) the flow of heat can be controlled with maximum precision.

Take care when changing hot nozzles! When using the heat gun in the self-resting position, make sure it is standing on a stable, non-slip and clean surface.

HL 1610 S

The tool is switched ON and OFF at the two-stage switch on the back of the grip handle. Airflow and temperature can be adjusted to 2 settings. Stage 1 reaches 575 °F at an air flow of 8.5 cf/min, stage 2 reaches 950 °F at 14.8 cf/min.

HL 1810 S

The tool is switched ON and OFF at the three-stage switch on the back of the grip handle. Airflow and temperature can be adjusted to 3 settings. Stage 1 is a Cool air stage at 120 °F with an airflow rate of 3.6 cf/min. Stage 2 reaches 750 °F at an airflow of 10.0 cf/min., stage 3 delivers 1100 °F at 15.9 cf/min. The outlet protection tube can be removed in order to install the overhead security hanger.

HL 1910 E

The tool is switched ON and OFF at the three-stage switch on the back of the grip handle. In addition to three-stage speed/airflow control (stage 1 is a "Cool-air stage" at 120 °F), temperature can be continuously adjusted over a range of 120 °–1100 °F at the thumbwheel. The numbers (1 to 9) on the thumbwheel serve as a guide only. Whereas "1" means 120 °F, the maximum temperature of 1100 °F is attained at "9".

Airflow can be adjusted to the three stages of 3.6/10.6/17.6 cf/min. The outlet protection tube can be removed in order to install the overhead security hanger.

Temperature Dial Setting	Temperature Range °F	Temperature Range °C	Sample Applications
1	100 – 160 °F	37.8 – 71.1 °C	cleaning surfaces
2	200 – 300 °F	93.3 – 148.9 °C	activating adhesives
3	375 – 475 °F	190.6 – 246.1 °C	shaping/removing flooring materials
4	475 – 575 °F	246.1 – 301.7 °C	welding PE, LDPE, PP, thawing pipes
5	600 – 700 °F	315.6 – 371.1 °C	welding ABS, PBT, PC; lap welding plastic sheeting
6	725 – 825 °F	385.0 – 440.6 °C	de-soldering circuit boards
7	850 – 950 °F	454.4 – 510.0 °C	stripping paint, loosening nuts/screws
8	975 – 1075 °F	523.9 – 579.4 °C	de-soldering copper pipes
9	1025 – 1125 °F	551.7 – 607.2 °C	soldering

HL 2010 E

The tool is switched ON and OFF at the three-stage switch on the back of the grip handle. In addition to three-stage speed/airflow control, temperature can be continuously adjusted over a range of 120 °–1150 °F by the pushbuttons. The target temperature can be increased in 10 °F steps by pressing the "+" side of the temperature pushbutton or reduced by pressing the "-" side of the temperature pushbutton. Pressing the button briefly increases or reduces the target temperature by one 10 °F step. Keeping the button pressed will continue to increase or reduce the temperature in steps of 10 °F until the button is released or the minimum or maximum temperature is set.

Blower stage 1 delivers a temperature of 120 °F. The tool will take a short while to cool to 120 °F after switching down to blower stage 1 when it has been operating at high temperatures on blower stage 2 or 3. While the tool is cooling down, the LCD display shows the actual temperature at the nozzle outlet. After switching OFF, the tool stays in the last setting. The outlet protection tube can be removed in order to install the overhead security hanger.

Features - Getting started

HG 2310 LCD / HG 2510 ESD

Operation

The tool is switched ON and OFF at the multi-stage switch on the back of the grip handle. The distance from the object you are working on depends on material and intended method of working. Always try out the air flow and

temperature on a test piece first. Using the attachable accessory nozzles the flow of heat can be controlled with maximum precision. **Take care when changing hot nozzles!**

When using the heat gun in the self-resting position, make sure it is standing on a stable, non-slip and clean surface. The outlet protection tube can be removed in order to install the overhead security hanger.

Setting the temperature

Stage 1 is the cool air stage. Use the cool air function for drying paint, cooling workpieces or to cool the nozzle before changing an accessory attachment. In stage 2 temperature can be infinitely varied over a range of 120 °F to 1200 °F on the control panel with LCD display. The actual temperature is measured at the nozzle outlet and indicated on the

display. The red push button on the left-hand side is used as an input button with minus/plus function. Temperature settings range from 120 °F to 1200 °F max. Briefly pressing the "+"/"-" push button increases or reduces the temperature setting in 10 ° steps. Pressing the button for longer speeds up the temperature setting process. Once the tempera-

ture has been set, the tool takes a few seconds to reach temperature (depending on speed/airflow). If you want to alter the setting, simply press either button to increase or reduce the temperature. After switching OFF, the heat gun stays in the last setting.

Setting airflow

The grey button panel on the right below the display is used for regulating airflow and blower speed. Airflow can be controlled in sever-

al stages using the "+/-" function and can be varied from a minimum of 3.6 cf/min. to a maximum of 17.6 cf/min. Use the cool

air stage function for drying paint, cooling workpieces or to cool the nozzle before changing an accessory attachment.

Programming [P]

Four programs are factory-set for the most common types of work. Press button "P" for programming mode. Number 1 is displayed for program 1. Continuing to press the program button will take you to programs 2 – 4. Pressing the button again will return the tool to normal operation.

Default programs

Program	Temp. °F	Air cf/min.	Application
1	480	approx. 12.4	Shrink tubing
2	660	approx. 14.8	De-soldering circuit boards
3	860	approx. 17.6	Forming plastics
4	1000	approx. 14.8	Soldering

Memory function [S]

The settings for the four programs can be changed and saved at any time. To do this, press the first program button "P" until the display shows the program you wish to change. Set the chosen airflow

and temperature. Now press the memory button "->" until the "->" symbol is cleared from the display (approx. 5 sec). The values entered are now saved in the program memory. To return to

normal operation, press the program button until the program symbol disappears from the display.

"LOC" function

Authorized quality Control personnel may lock down the heat gun's output to one specific tempera-

ture/airflow combination using the "LOC" Lockable Override Control™ feature.

Please call (800) 852-4343 for more information.

Applications

Here are some of the applications you can use STEINEL heat guns for. This selection is by no means exhaustive – no doubt you can immediately think of other examples.

(A) Stripping paint: Paint is softened and can be removed with a stripping knife and paint scraper to leave a clean surface.

(B) Shrinking tubing on cables: The shrink tubing is slipped over the section you want to insulate and heated. The tubing shrinks by approx. 50% in diameter to give a sealed union. Shrinking is particularly fast and even using reflector nozzles. Sealing and stabilizing cable breaks, insulating soldered joints, gathering cable runs, sheathing terminal blocks.

(C) Forming PVC: Sheeting, piping or ski boots can be softened and formed with heat.

(D) Lighting the barbecue: Gets charcoal glowing in next to no time; no more waiting.

(E) Thawing: Water pipes, frozen door locks, steps. Gently thaws and dries all in one go.

(F) Soft soldering: First, clean metal parts you want to join. Then, heat the point you want to solder and offer up the soldering wire. Use flux or a soldering wire with a flux core to prevent oxide forming.

(G) Welding and joining plastic: All parts being welded must be of the same plastic material. Use an appropriate welding rod.

(H) De-soldering: Circuit boards and other electronic components may be soldered or de-soldered using a reduction tip fitted on an electronic heat gun.

(I) Joining sheeting: The sheets are overlapped and welded together. A slit nozzle is used to direct heat under the overlap, then the two sheets are firmly pressed together with a feed roller. Also possible: **Repairing PVC tarpaulins** by overlap welding with a slit nozzle.

Material	Application types	Distinguishing characteristics
Rigid PVC	Pipes, fittings, sheets, building profiles, technical mouldings Welding temperature 580 °F	Carbonizes in the flame, pungent odour; crashing sound
Plasticised PVC	Floor coverings, wallpapers, hoses, sheets, toys Welding temperature 760 °F	Smoking, yellowish-green flame, pungent odour; silent
Soft PE (LDPE) Polyethylene	Domestic and electrotechnical articles, toys Welding temperature 480 °F	Light yellow flame, drips continue to burn, smells of a candle being extinguished; dull sound
Hard PE (HDPE) Polyethylene	Baths, baskets, canisters, insulating material, pipes Welding temperature 580 °F	Light yellow flame, drips continue to burn, smells of a candle being extinguished; crashing sound
PP Polypropylene	HT drainage pipes, moulded seats, packaging, car components Welding temperature 480 °F	bright flame with a blue core, drips continue to burn, pungent odour; crashing sound
ABS	Car components, equipment housings, cases Welding temperature 660 °F	black, fluffy smoke, sweet odour; crashing sound

(J) Accessories

Your dealer has a wide range of accessories for you to choose from. (* for HL 1910 E, HL 2010 E, HG 2310 LCD and HG 2510 ESD only)

- | | | | |
|---|---|---|---|
| 1 Spreader nozzle, 75 mm
Prod. No. 07011 | 8 Deflector nozzle, 75 mm
Prod. No. 07031 | 13 Reflector nozzle, 75 mm
Prod. No. 07301 | 20 Angle slit nozzle
Prod. No. 07511 |
| 2 Spreader nozzle, 50 mm
Prod. No. 07021 | 9 Deflector nozzle, 50 mm
Prod. No. 07041 | 14 Reflector nozzle, 39 mm
Prod. No. 07051 | 21 Wire protection tube
Prod. No. 07402 |
| 3 Butt welding disc, 80 mm*
Prod. No. 07211 | 10 Seam roller, 45 mm
Prod. No. 01250 | 15 Reflector nozzle, 14 mm*
Prod. No. 07461 | |
| 4 Lap welding slit tip
Prod. No. 07471 | 11 Plastic welding rods
Prod. No.
Rigid PVC 07311
LDPE 07331
HDPE 07121
PP 07341
ABS 07421 | 16 Reflector nozzle, 9 mm
Prod. No. 07061 | |
| 5 Welding rod tip
Prod. No. 07091 | | 17 Reducer nozzle, 9 mm*
Prod. No. 07062 | |
| 6 Lap welding slit tip
Prod. No. 07101 | | 18 Reducer nozzle, 14 mm*
Prod. No. 07071 | |
| 7 Rod welding slit tip
Prod. No. 07201 | 12 Overhead Security Hanger
Prod. No. 01481 | 19 Reducer nozzle, 20 mm*
Prod. No. 07081 | |

HL 1610 S / HL 1810 S / HL 1910 E / HL 2010 E / HG 2310 LCD / HG 2510 ESD

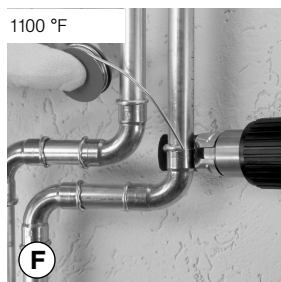
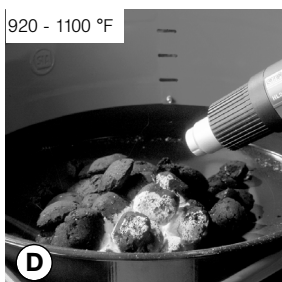
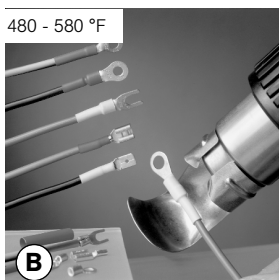

HL 1910 E / HL 2010 E / HG 2310 LCD / HG 2510 ESD

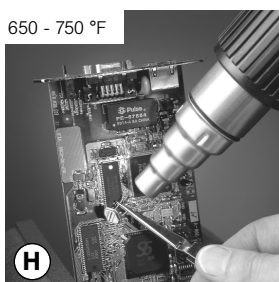
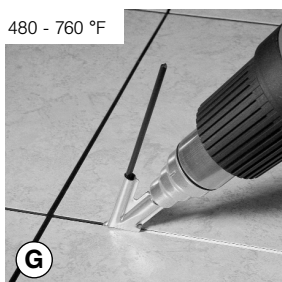

J Accessories



Spare Parts List HL 1610 S

	Pos.	Part No.
HL 1610 S, Type 3480		
Housing Set incl. Labels	1+2	02816
Switch with Markings (external)	3	02416
Power Cord with Strain Relief	4+5	02723
Power Cord Connector	6	—
Set of 5 Housing Screws	7	02829
PCB/C Block with Switch (internal)	8	02316
Motor/Fan Assembly	9	02216
Heating Element 1300W/120V	10	02116
Switch (internal)	11	02417

Wiring Diagram HL 1610 S

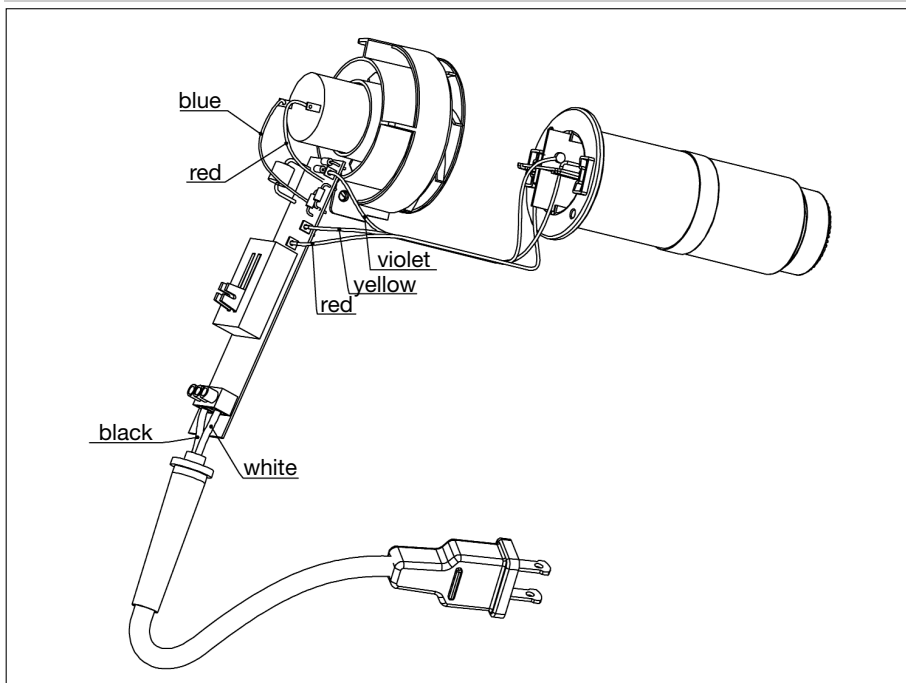

Spare Parts List HL 1810 S

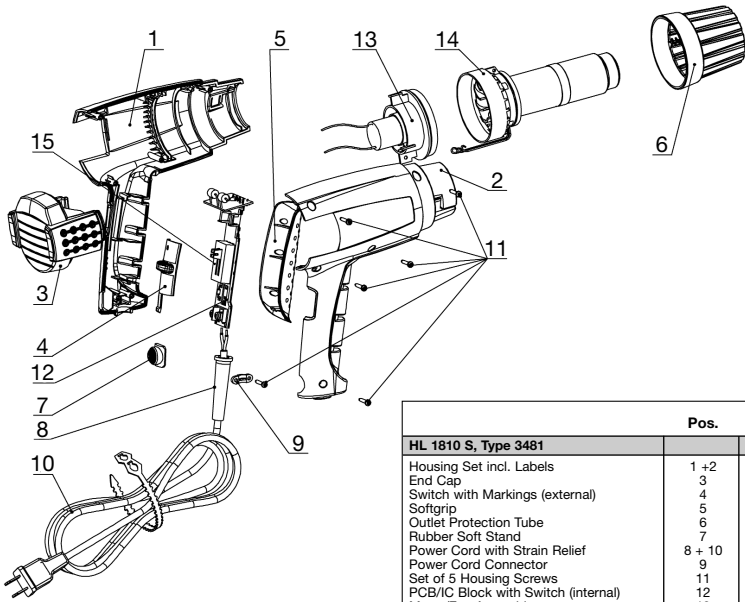

	Pos.	Part No.
HL 1810 S, Type 3481		
Housing Set incl. Labels	1 + 2	02818
End Cap	3	—
Switch with Markings (external)	4	02420
Softgrip	5	02821
Outlet Protection Tube	6	02523
Rubber Soft Stand	7	02629
Power Cord with Strain Relief	8 + 10	02723
Power Cord Connector	9	—
Set of 5 Housing Screws	11	02829
PCB/IC Block with Switch (internal)	12	02318
Motor/Fan Assembly	13	02218
Heating Element 1400W/120V	14	02118
Switch (internal)	15	02426

Wiring Diagram HL 1810 S

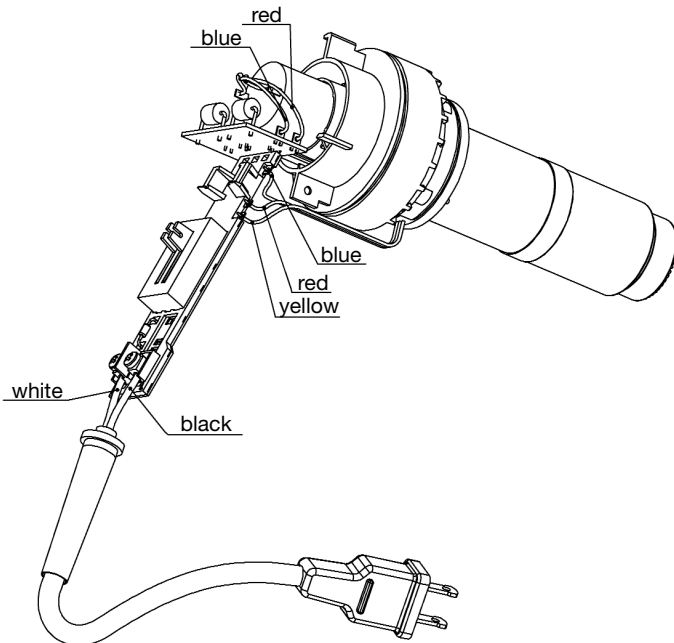

Spare Parts List HL 1910 E

	Pos.	Part No.
HL 1910 E, Type 3484		
Housing Set incl. Labels	1 + 2	02819
Switch with Markings (external)	3	02420
Softgrip	4	02621
Rubber Soft Stand	5	02629
Power Cord with Strain Relief	6 + 8	02723
Outlet Protection Tube	7	02523
Power Cord Connector	9	—
Set of 5 Housing Screws	10	02829
PCB/IC Block with Switch and End Cap	11	02319
Motor/Fan Assembly	12	02225
Heating Element 1500W/120V	13	02120
Switch (internal)	14	02426

Wiring Diagram HL 1910 E

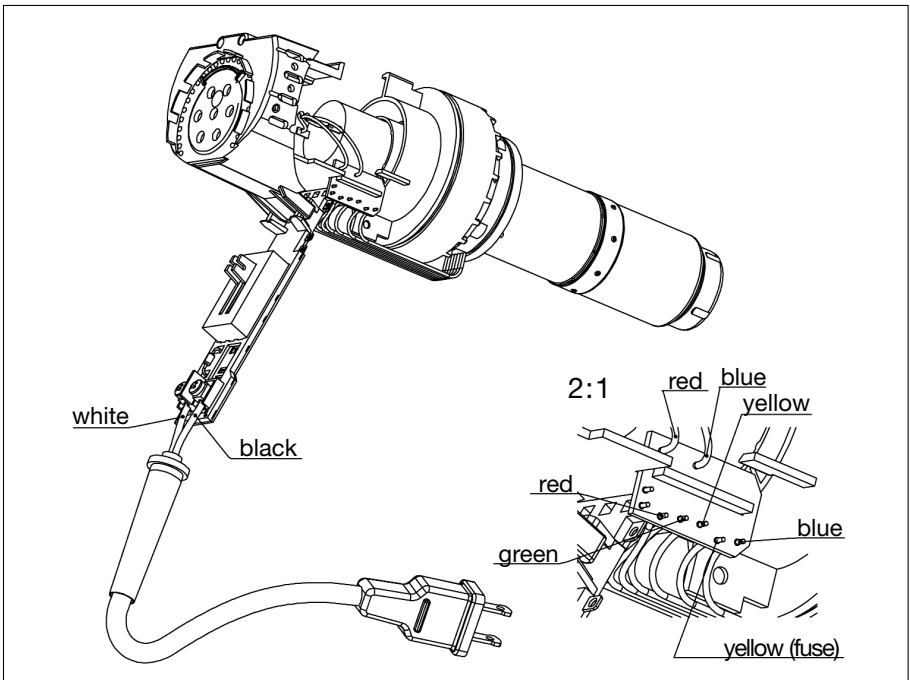

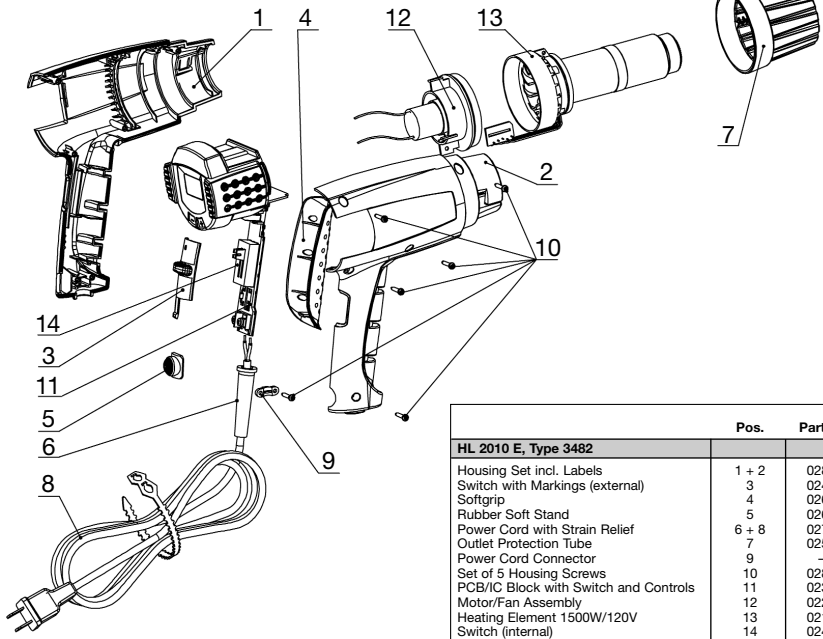
Spare Parts List **HL 2010 E**

	Pos.	Part No.
HL 2010 E, Type 3482		
Housing Set incl. Labels	1 + 2	02820
Switch with Markings (external)	3	02420
Softgrip	4	02621
Rubber Soft Stand	5	02629
Power Cord with Strain Relief	6 + 8	02723
Outlet Protection Tube	7	02523
Power Cord Connector	9	—
Set of 5 Housing Screws	10	02829
PCB/IC Block with Switch and Controls	11	02320
Motor/Fan Assembly	12	02225
Heating Element 1500W/120V	13	02120
Switch (internal)	14	02426

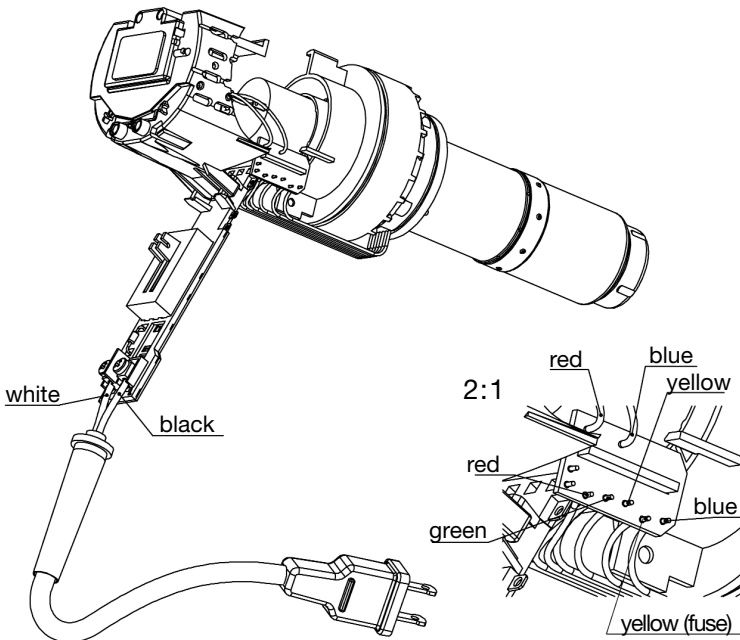
Wiring Diagram **HL 2010 E**

Spare Parts List HG 2310 LCD

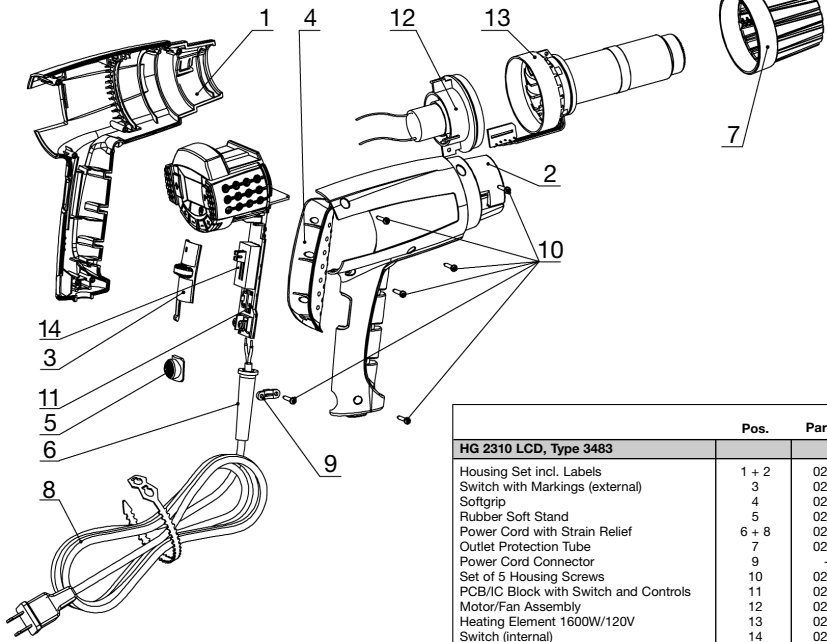

	Pos.	Part No.
HG 2310 LCD, Type 3483		
Housing Set incl. Labels	1 + 2	02823
Switch with Markings (external)	3	02423
Softgrip	4	02621
Rubber Soft Stand	5	02629
Power Cord with Strain Relief	6 + 8	02723
Outlet Protection Tube	7	02523
Power Cord Connector	9	—
Set of 5 Housing Screws	10	02829
PCB/C Block with Switch and Controls	11	02323
Motor/Fan Assembly	12	02225
Heating Element 1600W/120V	13	02123
Switch (internal)	14	02426

Wiring Diagram HG 2310 LCD

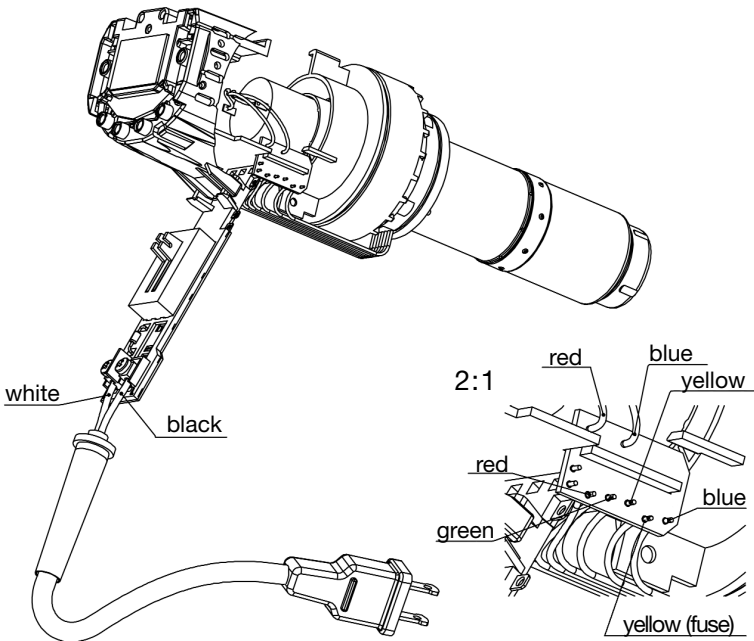

Spare Parts List HG 2510 ESD

	Pos.	Part No.
HG 2510 ESD, Type 3488		
Housing Set incl. Labels (ESD)	1 + 2	02825
Switch with Markings (external)	3	02425
Softgrip	4	02621
Rubber Soft Stand	5	02629
Power Cord with Strain Relief (ESD)	6 + 8	02725
Outlet Protection Tube (ESD)	7	02525
Power Cord Connector	9	—
Set of 5 Housing Screws	10	02829
PCB/C Block with Switch and Controls (ESD)	11	02325
Motor/Fan Assembly	12	02225
Heating Element 1600W/120V (ESD)	13	02125
Switch (internal)	14	02426

Wiring Diagram HG 2510 ESD

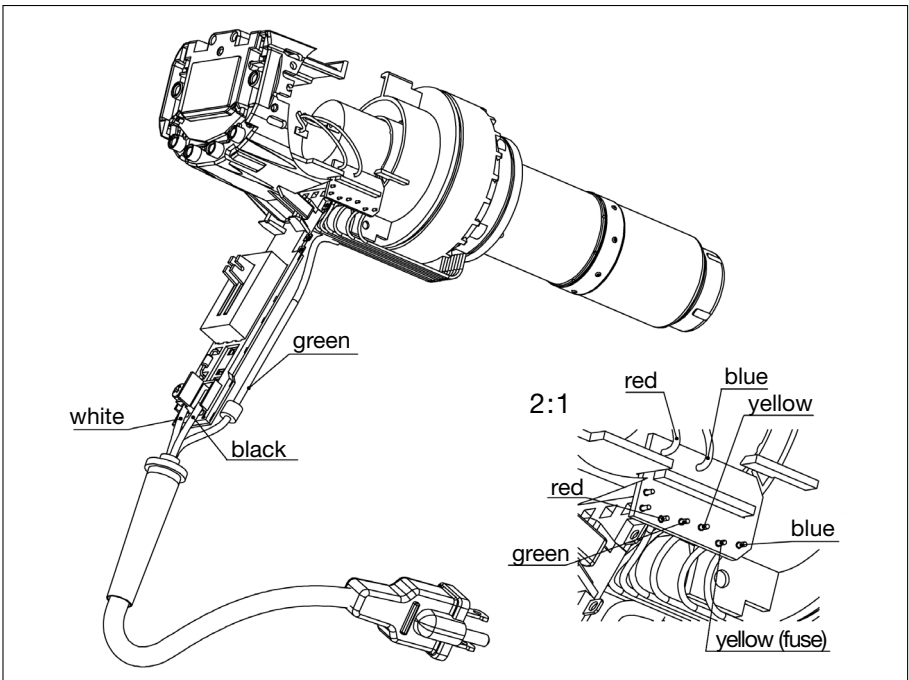

Limited Warranty

STEINEL warrants its heat guns and glue guns, if properly operated and maintained, and used under normal conditions, for a period of one (1) year from the date of purchase. For heat guns, this warranty includes the heating element. Specifically EXCLUDED from warranty are tools that have been subject to abuse, tools that have been opened or repaired by anyone other than STEINEL, tools that have been modified in any way or mounted onto machinery/equipment, and tools that have been put into continuous operation. These are hand held power tools and are intended for use as such. Any other use voids STEINEL's warranty.

Warranty and Repair Procedures

In the event of product failure, please call STEINEL customer service directly at (800) 852-4343. We will attempt to troubleshoot the difficulty via phone. If warranty work or other repair appears necessary, we will issue an RGA# and ask that the tool be returned to us at the below address (postage paid by the customer), with the RGA# clearly marked, and accompanied by a brief description of the difficulty as well as your original dated sales receipt phone number and return address.

When received, STEINEL will diagnose the problem and determine if it is covered under warranty. If we determine that it is covered by warranty, we will repair or replace the defective tool, at our option, and return it to the customer (postage paid by STEINEL). If we determine that the tool is not defective and/or that it is not covered by warranty, we will contact the customer to discuss his options prior to performing any repair work not covered under warranty. All non-warranty repair work is billed at standard rates and will be quoted prior to repair.

Consequential Damages

The company shall not be liable for any incidental or consequential damages arising from the use of the Product by the Purchaser, the breach of any warranties, the failure to deliver, delay in delivery, delivery in non-conforming condition, or for any other breach of contract or duty between the Company and the Purchaser.

Some states do not allow the exclusion or limitation of incidental or consequential damages, so the above limitation or exclusion may not apply to you.

Disclaimers of warranties

The warranties contained herein are expressly in lieu of any other expressed or implied warranties, or any other obligation on the part of the Company. Any implied warranty of merchantability or fitness for a particular purpose shall expire one (1) year after the date the product is purchased by the original end-user Purchaser. Any models, drawings, plans, specifications, affirmations of fact, promises, or other communications by the Company with reference to the performance of the product are solely for the convenience of the Purchaser and shall not in any way modify the expressed warranties and disclaimers set forth herein. The Purchaser acknowledges it is purchasing the Product solely on the basis of the commitments of the Company as expressly set forth herein. No agents or other parties are authorized to make any warranties on behalf of the Company or to assume for the Company any other liability in connection with the Product. Some states do not allow limitations on how long an implied warranty lasts, so the above limitation may not apply to you.

Limitation of actions

Any action resulting from the breach of any warranty contained herein by the Company must be commenced within one (1) year after the cause of action accrues. In no event shall the Company's total liability for any or all breaches of any warranty exceed the actual purchase price of the Product.

Other rights

This warranty gives you specific legal rights, and you may also have other rights which vary from state to state.

STEINEL

9051 Lyndale Avenue South
Bloomington, MN 55420
Tel.: 952-888-5950
Fax: 952-888-5132
Toll free: 1-800-852-4343

E-mail: sales@steinel.net
Visit our website: www.steinel.net

FUNCTIONAL

12 month

WARRANTY

STEINEL[®]

German Quality

000000 Subject to technical change without prior notice